

KOHREE

User Manual

KOHREE

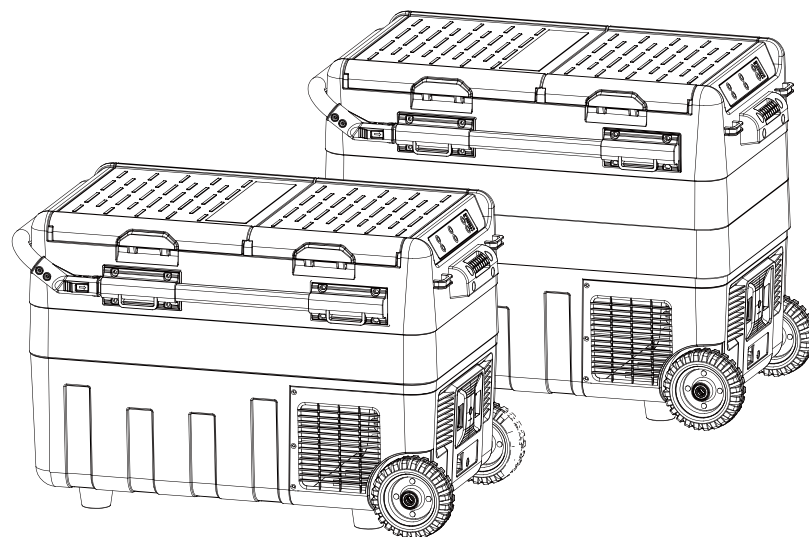

CAR REFRIGERATOR WITH
COMPRESSOR

To create a cool trip for worldwide car lovers

● Attentions

- △ Before using the refrigerator, please read this manual carefully and keep it properly
 - ⊙ Before the first use of refrigerator, you should clean it inside and outside with a damp cloth.
 - ⊙ Do not fill the refrigerator with corrosive liquids. Do not directly pour liquids into the refrigerator.
 - ⊙ When the refrigerator is not used for a long time, please disconnect the power supply and keep it dry.
 - ⊙ Please clean the inner chamber regularly to prevent odor bacteria and ensure food safety.
 - ⊙ Shut down the refrigerator and battery before pulling by the trolley (If with battery).
- △ Connect the power supply
 - ⊙ Find the DC power cord in the kit. Connect DC plug to the power outlet of the car refrigerator.
 - ⊙ Well place the refrigerators in the car (back-up, seats...)
 - ⊙ Lay out power cords as per the interior space of your car. Insert the cigarette lighter plug (one side of the power cord) into the car cigarette lighter hole.



Adapter



Connect the car cigarette lighter



DC 12/24V

Connect the car refrigerator

Connect the car cigarette lighter / DC Power Cord / Connect the car refrigerator (Standard mode) / Connect the car refrigerator (Built-in Mode)

The refrigerator can be connected to more than one source of energy.

The refrigerator can be directly connected to the 12V/24V DC power supply.

If the refrigerator is used in 100-240V power supply, an AC adapter should be adopted.

● Component diagram

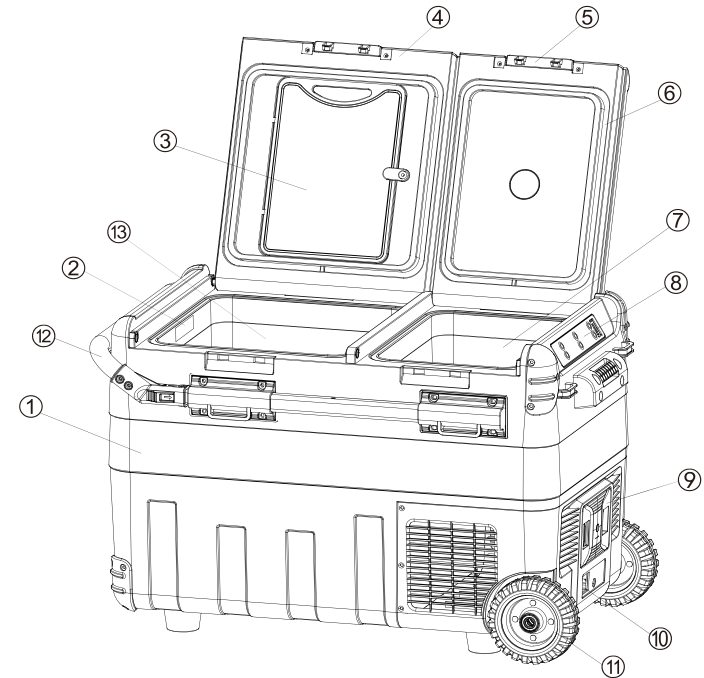

- | | | | |
|-----------------------|---------------------|---------------------|-----------------|
| ① Cabinet | ② Inner light | ③ Cutting board | ④ Case Cover |
| ⑤ Door buckle | ⑥ Door gasket | ⑦ Small compartment | ⑧ Control panel |
| ⑨ Battery compartment | ⑩ Power connector | ⑪ Wheels | |
| ⑫ Handle | ⑬ Large compartment | | |

● Operation Method

! WARNING!

Condensation or ice may appear around door gasket and front of cabinet if the fridge runs for long time. It's normal. Please clean the condensation or ice with dry towel.

! WARNING!

The fridge is designed for outdoor camping, not suitable for long term freezing food.

! WARNING!

To save energy and avoid condensation or ice issue, please not run the fridge with setting lower than 0°C/32°F for long term.

! WARNING!

Defrost water may leak from inner compartment of cabinet if the fridge is powered off or stood by for a long time. It's normal. Please clean the inner side by dry towel if you plan to depose the fridge.

Dual zone with individual temperature control

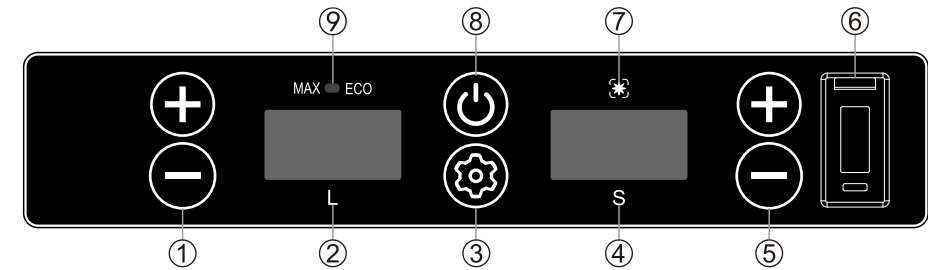

- ① Setting for large compartment
- ② large compartment
- ③ Setting button
- ④ Small compartment
- ⑤ Setting for small compartment
- ⑥ USB socket
- ⑦ Cooling indicator
- ⑧ ON/OFF button
- ⑨ Max/Eco

Turn On/Off

Press ⑧ key to turn on/standby the refrigerator.

Set temperature

- ① Switch on the fridge, press ④ to rise setting temperature and ⑤ to reduce the setting temperature of storage compartment.
Setting temperature of two compartments ranges from -20°C(-4°F)~+20°C(+68°F).
- ② The temperature display will flash for 3 seconds and then fix the setting after adjusting temperature and no more action on buttons. The setting temperature will be memorized and the display will turn back to show real temperature of storage compartment.

MAX / ECO Mode Conversion

Directly press ⑨ key to switch MAX mode or ECO mode.
MAX mode (white light): Powerful cooling
ECO mode (green light): Energy-saving cooling

Set car battery protect level



Car Battery Protection Voltage Reference

Built-in ECO electronic control module can automatically monitor car battery voltage. Refrigerator will be automatically cut off when the power is excessively consumed, So that protecting the battery consumption from too low to affect auto ignition.

Voltage	High Level set to be factory default (Voltage Protection)		
	H1 (High) level	N2 (Medium) level	L3 (Low) level
12V	11.3V OFF, 12.5V ON	10.1V OFF, 11.4V ON	8.5V OFF, 9.6V ON
24V	24.6V OFF, 26V ON	22.3V OFF, 23.7V ON	21.3V OFF, 22.7V ON



NOTE: when the refrigerator is on work, "OFF" or "ON" is the stop or start of the compressor.

Battery Protection Levels: H1 (High) → N2 (Medium) → L3 (Low)

Press  key for 3s to enter the battery protection setting. Press  key again to switch H1 → N2 → L3 levels in turns.

If no operations were detected, the set level will flash for 3s, then exit and save the current setting.

Celsius (°C) / Fahrenheit (°F) Conversion

Change temperature unit between °C and °F by press  and  of large compartment for 3 seconds after switch on the fridge.

Power-off Memory Function

There is a power-off memory function for the car refrigerators. When the power is lose, working state (On/Off status, working mode etc.) which before power-off can be automatically recovered at the next startup, no need to set it again.

NOTE: It is recommended to use the large zone as a fridge(for fresh food) and the small zone as a freezer(for frozen food).

Use the handle

WARNING: when you use handle to move the fridge, please smoothly pull, NOT hastily throw the handle. It's possible to break the handle. If the ground is not flat, it's better to not use handle to move the fridge.

Unlock the handle and then pull out the handle as below

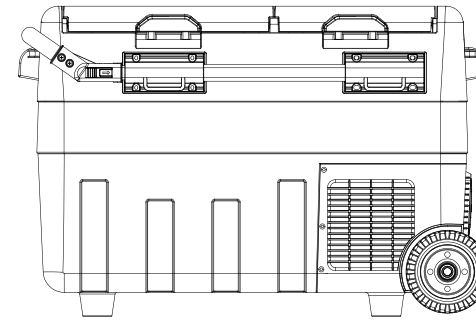

Front lock

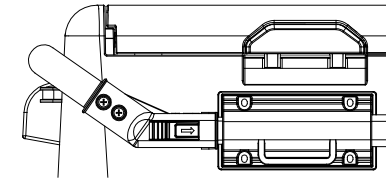

Unlock →

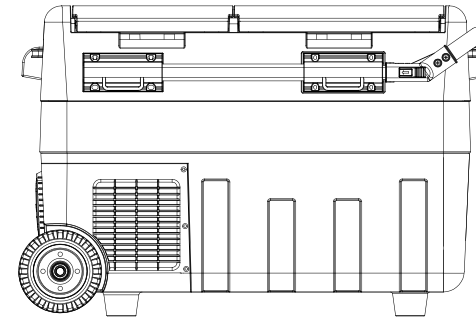

Rear lock

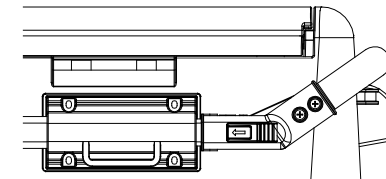

Unlock ←

● Troubles and Troubleshooting

Advice: If there is any abnormal situations that cannot be resolved through simple fault analysis, please contact professional customer service for assistance.

△ Car Refrigerator Does Not Work

- Check if the power is connected properly. (check if the plug is loosened or positive and negative poles are reversed).
- Check if the power switch on the operation panel is turned on.
- Check if the cooling ventilation is normal.
- Check if the fuse is blown.

△ Poor Cooling Performance

- Check if the lid is closed properly
- Check if the door seal is damaged or deformed.
- Check if there is poor ventilation around the fridges.
- Check if the temperature is set properly.

△ Abnormal Noise

- Refrigerator is not put on a flat level surface
- Check for vibrations in surrounding objects
- Parts in the refrigerator get loose or fall off.

△ Refrigerator Condensation

- It is normal that there slightly will be some condensation on the refrigerator surface when air humidity is more than 75%.

△ Definition Of Error Codes On The Display

Error Code	Error Type
E1	Low Input Voltage
E2	Fan Fault
E3	Input Voltage Fault due to compressor starts frequently
E4	Low Rotational Speed of Compressor
E5	Overheating of Controller Chip
E6	Open or Short Circuit of NTC

● Failures and Solutions

△ E1: Low Input Voltage

- Failure 1: Insert refrigerator power cord into cigarette lighter before the car starts.
Solution 1: Wait for a while to connect the car after it started.
- Failure 2: Input voltage of the adapter is too low.
Solution 2: Adjust the battery protection level to middle-voltage or low-voltage. If it doesn't work, please replace a new adapter.

△ E2: Fan Fault

- Please replace a new fan when identify there is a fan malfunction.

△ E3: Input Voltage Fault due to compressor frequently start

- When the refrigerator is used in car and E3 appearing
 - ① Please shut down for 5 minutes and restart it.
 - ② If it doesn't work, that can be identified to be E1 fault, please solve it according to the solution of E1.
- When the refrigerator is connecting with adapter and E3 appearing
 - ① Please adjust battery protection level to the middle level or low level.
 - ② If it doesn't work, please replace a new adapter.









△ E4: Low Rotational Speed of Compressor

- Please adjust input voltage and repower it.

△ E5: Overheating of Controller Chip

- Please power off for 5 minutes and check if the overheating is caused by the bad ventilation around compressor.

● Applications

-  With an additional battery, you can hold any temperature you set in any situations without worries.
-  When storing ice cream in refrigerator, please set to the lowest temperature and keep power on constantly.
-  Prevent healthy problems from bottled water deterioration caused by the high temperature.
-  Keep fresh for the frozen food and luxurious seafood during the long travelling.
-  Freshness of tealeaves is effectively preserved by car refrigerator, you can enjoy the fresh and delicious tea any time during the self-driving travelling.
-  Coating of sunglasses will drop off at the high temperature, car refrigerator is the best ideal place to put away.
-  Cosmetic is easy to go bad at high temperature, so the best choice to store outside is with a car refrigerator.
-  Ideal storage temperature for red wine is 10°C-15°C, the precise temperature control of car refrigerator guarantee the storage temperature for it.
-  Fruits cannot be kept in hot car for more than 2 hours, even it is in the air conditioning. But car refrigerator is able to effectively keep the fruit fresh for a long time.

● Safety Attention

- ⊙ Ensure proper connecting of voltage for the refrigerator at any time. (Parameter label shows the approved voltage for car refrigerator).
- ⊙ Do not directly pour any liquid into the car refrigerator.
- ⊙ It is forbidden to modify the refrigerators privately, in case of dangers.
- ⊙ Refrigerators should not be exposed to the rain.
- ⊙ Do not lean the fridge during running to avoid damage of inner parts.

